

NAF-Check
Non-Return Valves
PN 10 – 100
DN 40 – 1000 (1½" – 40")



Issue date: 12/99

Non-Return Valves
PN 10 – 100
DN 40 – 1000
(1½" – 40")
NAF-CHECK

A₂

Application

for liquids, gases, vapours, corrosive fluids and low temperatures.

Types

Steel

Type	PN	DN (mm)	Version
526 620	10-40	40-250 1½" - 10"	without spring
526 630	10-40	65-250 2½" 10"	with spring
526 520	10-25	300-1000 12" - 40"	without spring
526 530	10-25	300-1000 12" - 40"	with spring

Stainless steel

Type	PN	DN (mm)	Version
528 620	10-40	40-250 1½" - 10"	without spring
528 630	10-40	65-250 2½" 10"	with spring
528 520	10-25	300-1000 12" - 40"	without spring
528 530	10-25	300-1000 12" - 40"	with spring

High-temperature steel

Type	PN	DN (mm)	Version
526 822	40-100	65-400 ¹⁾ 2½" - 16"	without spring
526 832	40-100	65-400 ¹⁾ 2½" - 16"	with spring

¹⁾ DN 400 only for PN 40 and 63

Pressure/Temperature Rating

Steel at -10°C and nominal pressure

Type	PN	DN (mm)	Max. service pressure in [bar g] and [psig]											
			40	40	40	38	36	32	25	18	11	-	-	
526 620/30	40	40-250 1½" - 10"	580	580	580	551	522	464	363	261	160	-	-	
526 520/30	25	300-1000 12" - 40"	363	363	363	348	319	290	218	160	87	-	-	
Related temperature ²⁾		°C	20	100	150	200	250	300	350	400	450	500	525	
		°F	68	212	302	392	482	572	662	752	842	932	977	

Stainless Steel at -40°C and nominal pressure

Type	PN	DN (mm)	Max. service pressure in [bar g] and [psig]											
			40	33	31	29	28	26	26	-	-	-	-	
528 620/30	40	40-250 1½" - 10"	580	479	450	421	406	377	377	-	-	-	-	
528 520/30	25	300-1000 12" - 40"	363	290	276	261	247	232	232	-	-	-	-	
Related temperature ²⁾		°C	20	100	150	200	250	300	350	400	450	500	525	
		°F	68	212	302	392	482	572	662	752	842	932	977	

High-temperature steel at -10°C and nominal pressure

Type	PN	DN	Max. service pressure in [bar g] and [psig]											
			100	100	100	100	100	100	100	97	85	54	37	
526 822/32	100	65-400 2½" - 16"	1450	1450	1450	1450	1450	1450	1450	1407	1233	783	537	
Related temperature ²⁾		°C	20	100	150	200	250	300	350	400	450	500	525	
		°F	68	212	302	392	482	572	662	752	842	932	977	

²⁾ Max. service temperature for valve with spring: + 300 °C (572 °F)

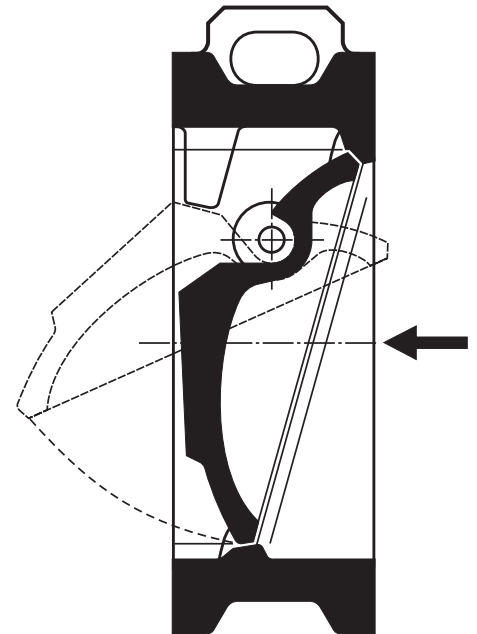

- Wafer-type valve for sandwiching between flanges
- Short overall length acc. to DIN EN 558-1, series 16 (≙ ISO 5752)
- Suitable for flanges to DIN, BS and ANSI

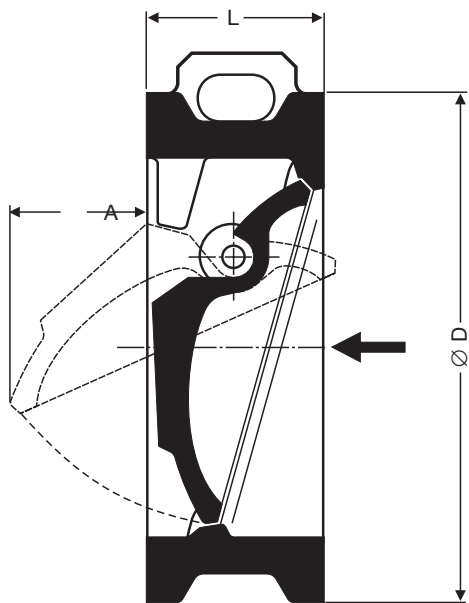

Dimensions, Weights

Type	PN	DN mm (inch)	D	L	A	Weight [kg]
526 620/30 528 620/30	10-40	40 (1½)	84	33	15	1.2
		50 (2)	92	43	5	1.7
		65 (2½)	108	46	12	1.7
		80 (3¼)	128	64	16	3
		100 (4)	158	64	26	5
		125 (5)	180	70	36	7
		150 (6)	203	76	51	9
		200 (8)	263	89	71	16
526 520/30 528 520/30	10-25	250 (10)	315	114	90	28
		300 (12)	370	114	125	41
		350 (14)	432	127	146	48
		400 (16)	480	140	175	65
		450 (18)	530	152	188	94
		500 (20)	592	152	228	115
		600 (24)	692	178	282	192
		700 (28)	804	229	301	270
526 822/32	40-100	800 (32)	911	241	374	402
		1000 (40)	1124	300	458	782
		65 (2½)	125	46	12	3
		80 (3¼)	138	64	16	4
		100 (4)	158	64	26	5
		125 (5)	188	70	39	9
		150 (6)	222	76	52	11
		200 (8)	275	89	73	23
		250 (10)	335	114	93	45
		300 (12)	394	114	131	57
350 (14)	435	127	151	75		
400 ³⁾ (16)	490	140	177	98		

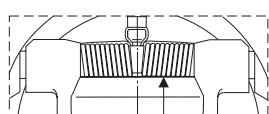

NAF-Check
with spring

The spring
can be easily
fitted or
removed
after delivery.

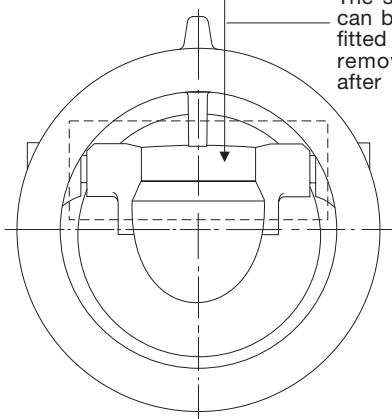

³⁾ DN 400 mm (16") only for PN 40/63

Connections of wafer-type valves

Valves for universal fitting between flanges to				
Type	DIN 2501	ANSI weld neck	BS 10 Table	BS 4504 Table
526 520/30, 528 520/30	PN 10/16/25	Class 150, DN 300-600	E, F, DN 300-600	10/2, 16/2, 25/2
526 620/30, 528 620/30	PN 10/16/25/40	Class 150, 300	E, F, H	10/2, 16/2, 25/2, 40/2
526 822/32	PN 40/63/100 ⁴⁾	Class 300, 400/600	H, J, K, R	40/2, 63/2, 100/2 ⁴⁾

⁴⁾ DN 400 (16") not for PN 100 (100/2)

Installation

The flow direction is indicated by an arrow on the lifting lug. Installation in horizontal lines (lifting lug on top) or vertical lines with upward flow.

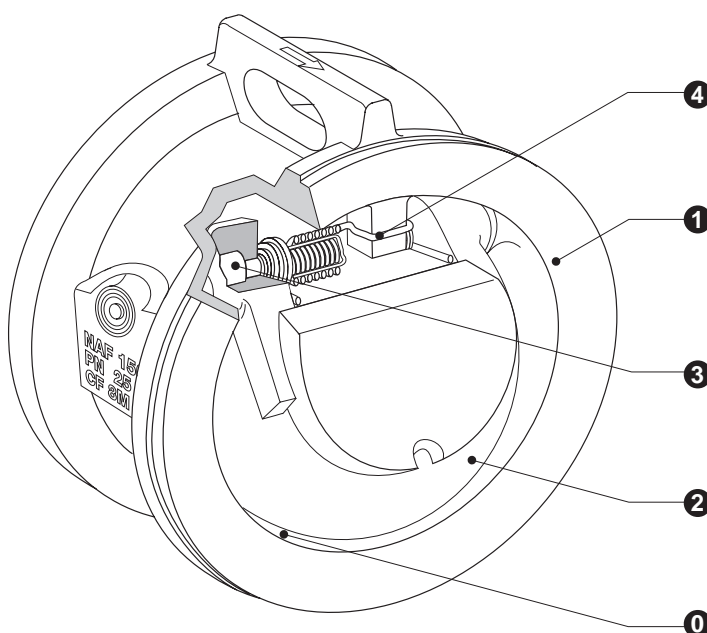

Materials

Version	Designation	Item no.	NAF specification	DIN equivalent	
Steel	Body DN 40+50 DN 65-250 DN 300-1000	1	SS 2343 (≙ ASTM, A 276 316)	X5CrNiNb 18 14 3	1.4436 ⁵⁾
			ASTM A 351 CF8M	X10CrNiMo 18 10	1.4581
			ASTM A 216 WCC	GP 240 GH (GS-C 25)	1.0619
	Disc DN 40+50 DN 65-1000	2	SS 2395 –	X2CrNiMoN 17 13 5	1.4439
SS 2387 –			X4CrNiMo 16 5	1.4418 ⁵⁾	
Hinge	3	SS 2303 (≙ ASTM, A 276 420)	X20Cr 13	1.4021	
Spring	4	SS 2388 –	X7CrNiAl 17 7	1.4568	
Stainless steel	Body DN 40+50 DN 65-1000	1	SS 2343 (≙ ASTM, A 276 316)	X5CrNiNb 18 14 3	1.4436 ⁵⁾
			ASTM A 351 CF8M	X10CrNiMo 18 10	1.4581
	Disc	2	SS 2324 (≙ AISI 329)	X8CrNiMo 25 5	1.4460
	Hinge	3	SS 2324 (≙ AISI 329)	X8CrNiMo 25 5	1.4460
Spring	4	SS 2388 –	X7CrNiAl 17 7	1.4568	
High-temperature steel	Body	1	ASTM A 217 WC6	GS-17CrMo 5 5	1.7357
			ASTM A 217 WC6	GS-17CrMo 5 5	1.7357
	Hinge	3	SS 2303 (≙ ASTM, A 276 420)	X20Cr 13	1.4021
	Spring	4	SS 2388 –	X7CrNiAl 17 7	1.4568

⁵⁾ cast steel

A₂

Non-Return Valves
PN 10 – 100
DN 40 – 1000
(1½" – 40")

NAF-Check



Pressure Drop Chart

The curves given in the chart are valid for water at 20 °C. To read the pressure drop for other fluids the equivalent water volume flowrate must be calculated and used in the graph.

The values indicated in the chart refer to valves with horizontal flow. With vertical flows insignificant deviations occur only within the range of partial opening.

The chart and flow characteristics are applicable up to and including PN 40. Higher PN increase the zeta values and pressure drops at the same flowrates by approx. 20 %. The k_v values decrease accordingly.

$$\dot{V}_w = \dot{V} \cdot \sqrt{\frac{\rho}{1000}}$$

\dot{V}_w = Equivalent water volume flow in [l/s] or [m³/h]

ρ = Density of fluid (operating condition) in [kg/m³]

\dot{V} = Volume of fluid (operating condition) in [l/s] or [m³/h]

Enquiry Specification

NAF-Check Non-Return Valve
Wafer design with extremely short overall length to DIN EN 558-1/-2, series 16 (K3)

Order Specification

NAF-Check, type 526... DN...
For flanges to DIN..., with(out) spring.

Fluid, flowrate, pressure and temperature.
Type of pipe flanges.

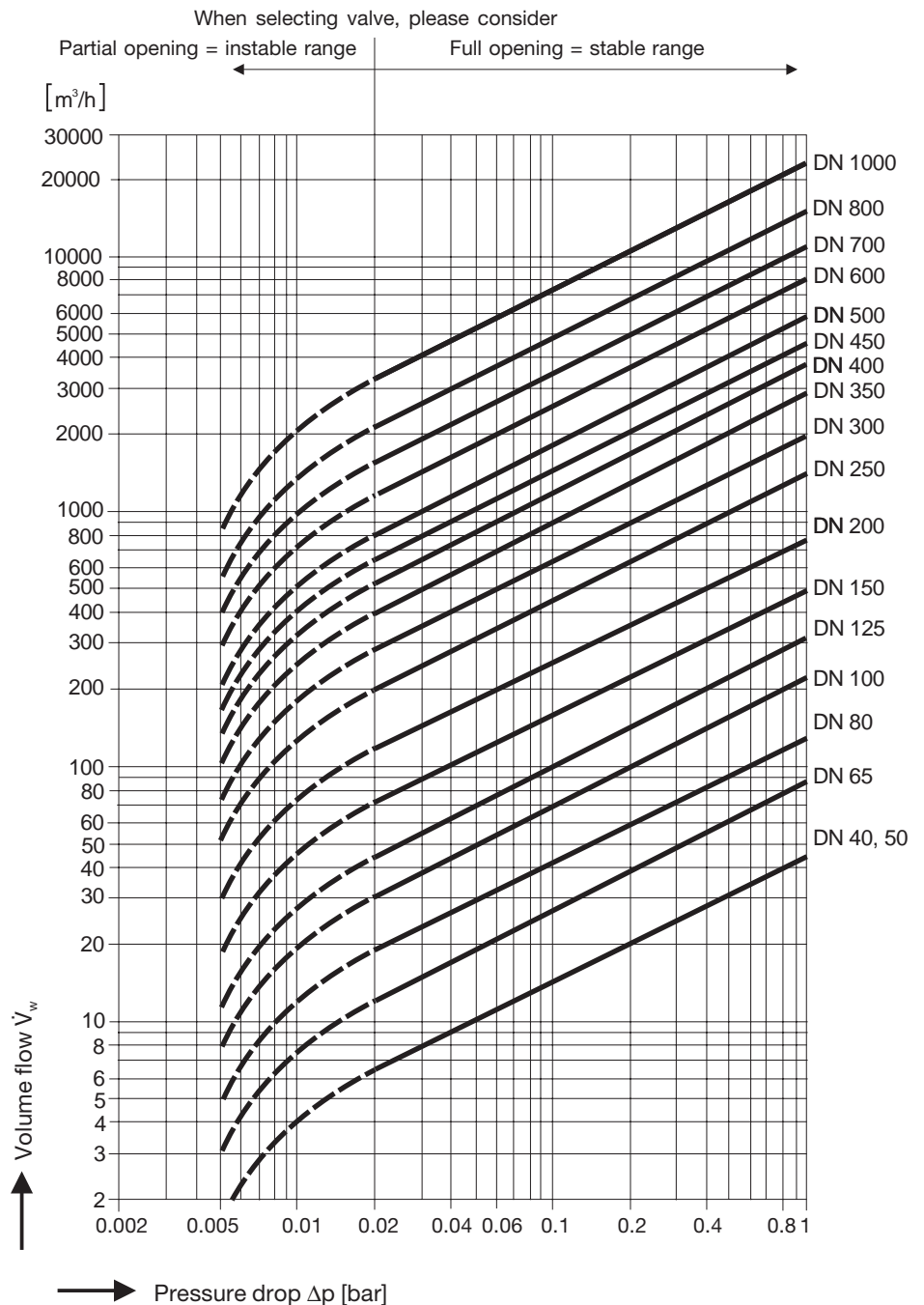

Flow characteristics

Installation in horizontal lines. Fluid: water at 20 °C.

Nominal size DN	Dual plate, fully open	
	Zeta values	K_v value [m³/h]
40+50	5.1	44.3
65	3.6	89.4
80	4.2	125
100	3.0	230
125	4.2	305
150	3.3	497
200	4.1	793

Nominal size DN	Dual plate, fully open	
	Zeta values	K_v value [m³/h]
250	3.7	1300
300	3.6	1900
350	3.3	2700
400	3.3	3500
450	3.3	4500
500	3.3	5500
600	3.3	8000
700	3.2	11000
800	2.9	15000
1000	2.9	23500

Please note:

The valves should not be used on compressors or where pulsating flow exists. For these applications please consult us.

Supply in accordance with our general terms of business.

Technical modifications reserved.